



Heavy-Duty Bypass System Installation and Servicing Instructions

IMPORTANT NOTICE

- Read **ALL** instructions completely.
- Improper installation can result in serious system and/or equipment damage. If you are uncomfortable with the instructions or have questions, **do not attempt installation**. Consult a mechanic or contact AMSOIL Technical Services at (715) 399-TECH for assistance.
- **WARNING:** Extreme care should be taken to avoid bodily harm during installation. Before beginning, ensure engine is cool to avoid burns. Never work in the engine compartment with the engine running. It is advised that you perform a full oil change with installation of this system.

A. BEFORE YOU BEGIN

1. Confirm all items on the Parts List are included in the Kit.
2. Ensure you have the required tools for the job.
3. Adapters to connect to your specific application must be purchased separately. These fittings must fit your application and the 1/2" JIC female end of the hose fitting.

RECOMMENDED TOOL LIST

- Torque wrench
- Drill
- 5/8" wrench
- 5/8" socket
- Side Cutter
- 7/16" drill bit
- Utility knife
- Center punch
- 7/8" wrench (2)
- Adjustable filter wrench
- Hammer
- Oil drain pan
- Vice
- Hose cutter

PARTS LIST

Heavy-Duty Bypass System (BMK30)

Item	Description	Qty.	Part No.
1.	Filter Mount Assembly	1	BK305
2.	Fitting, 13/32" Hose, 3/4"-16 JIC	4	BP260
3.	Washer, Flat, 7/16"	3	BP285
4.	Washer, Fender, 7/16"	3	BP286
5.	Bolt, 7/16"-14 x 1 1/2"	3	BP287
6.	Nut, Nylock 7/16"-14	3	BP288
7.	6" Nylon Cable Tie	6	BP46
8.	13/32" ID Hose	15 ft.	BP250
9.	Ea Bypass Filter	1	EaBP120
	Instruction Sheet	1	BP30

OPTIONAL PARTS (Not Included)

Description	Qty.	Part No.
Kit, Oil Sample Valve	1	BK30

See www.amsoil.com or contact your AMSOIL Dealer.

B. ATTACHING FILTER MOUNT

1. Survey the engine compartment for possible mounting locations. The mount should be located as close to the existing full-flow filter as possible. Select an area where the filtration system will not be damaged by road debris or off-road travel, and make sure the

mounting structure is adequate to carry the weight of the filtration system. Reference Diagram A for an approximation of space required for mounting the system and removing filters. Reference Diagram D for appropriate mounting angles.

2. When the mounting location has been determined, put the provided mounting template sticker in place. Using a center punch and hammer, mark the centers of the drilling locations.
3. Drill the center-punched holes on the template, remove the sticker and attach the BK305 using the (3) 7/16" bolts, nuts, small washers and fender washers provided. The bolts should be tightened to 40 ft-lbs.
4. Fill the EaBP120 with the same engine oil being used in the vehicle. Lubricate the filter gasket with oil and spin filter onto mount. Tighten per instructions on the filter.

- **NOTE:** All fittings on the BK309 have been installed to the proper torque. There is no need to make any adjustment to these fittings unless installing a BK30.

C. OIL SUPPLY

- **NOTE:** The hose and hose fittings supplied with this system are matched to provide maximum performance and life expectancy. Interchanging with other types or brands is not recommended and should be avoided. Should additional hose be required, it may be obtained from AMSOIL by ordering part number BP250 by the foot.
- **DO NOT** install oil hoses near hot exhaust parts or near sharp metal components that could cause abrasive wear.
- **DO NOT** create sharp bends in oil hoses when installing.

1. Locate a pressurized port such as a galley port, pressure sender port, etc. AMSOIL recommends adapting off the pressurized oil port using a fitting(s) to accept the 1/2" JIC female hose end provided in this system. **Purchase of adapters for your specific application is required.**

2. Measure the amount of hose (BP250) needed to run from the pressurized oil port to the **IN** port of the filter mount.

3. HOSE FITTING ASSEMBLY INSTRUCTIONS

- a. Using a utility knife or hose cutter, squarely cut the hose to the proper length (Step 3a).
- b. Install hose fittings (BP260) on both ends of the cut hose. Screw nut portion of the fitting **counter-clockwise** onto hose until it bottoms. Back hose out 1/2 turn (Step 3b).

- **NOTE:** Do not use any form of thread sealant anywhere on the hose fittings (BP260).

- c. Oil tapered nipple thread areas liberally with oil. You may also oil inside of hose. Do not oil hose cover (Step 3c).
- d. Screw nipple thread into socket using wrench on nipple hex until nipple hex shoulders against socket (Steps 3d, 3e, 3f).



4. Route and connect the hose assembly to the BK305 at the **IN** port and to the ½" JIC male fitting at the pressurized oil port.
5. On both ends tighten the nut finger-tight. Place a mark on the middle of one flat of the nut. Starting from this position, tighten the nut further by 1.5 flats using one wrench to hold the fitting and the other to turn the nut on the BP260. (A flat is referred to as one side of the hexagonal tube nut and equates to 1/6 of a turn.)

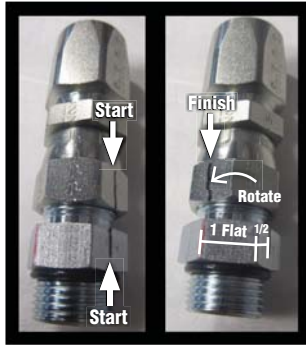

• **NOTE:** Do not use any form of thread sealant anywhere on the hose fittings.

D. OIL RETURN

1. The outlet of the BK305 should be connecting to a low-pressure or free oil return to the crankcase or sump of the engine. Many heavy-duty vehicles have access ports on the side of the oil pan or at the oil fill tube.
2. Measure the amount of hose (BP250) needed to run from the unpressurized oil port to the **OUT** port of the BK305.
3. Follow step C.3. for HOSE FITTING ASSEMBLY INSTRUCTIONS.
4. Route and connect the hose assembly to the BK305 at the **OUT** port and to the ½" JIC male fitting at the low pressure oil port.
5. On both ends tighten the nut finger-tight. Place a mark on the middle of one flat of the nut. Starting from this position, tighten the nut further by 1.5 flats using one wrench to hold the fitting and the other to turn the nut on the BP260. (A flat is referred to as one side of the hexagonal tube nut and equates to 1/6 of a turn.)

• **NOTE:** Do not use any form of thread sealant anywhere on the hose fittings.

6. Use plastic ties (BP46) to secure hose in position and away from components that could cause damage to the hoses. Trim ties using side cutter.

• **NOTE:** Overtightening the plastic ties can restrict oil flow.

E. START UP PROCEDURES

1. Check that all fittings and hoses are securely attached, and that the hoses are routed properly.
2. Check engine oil level. Fill to full mark on the engine dipstick if necessary.
3. With the equipment secured, start the engine and immediately check oil pressure. **NOTE:** Pressure may initially take a moment or two to rise.

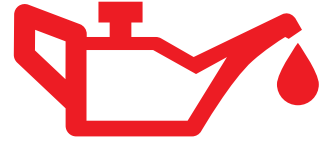

Caution: Carefully check for leaks at fittings, hoses and mount. If leaks are observed, **STOP ENGINE IMMEDIATELY**, repair leaks and continue.

4. After engine has warmed, shut off and re-check engine oil level. Top off as necessary.
5. Record date of installation and equipment operating hours or mileage.

F. PERIODIC MAINTENANCE

1. During the warranty period, annually inspect fittings and hoses. Check for leaks, hose deterioration and cuts. Repair and/or replace as necessary. See the AMSOIL Limited Warranty – Bypass Filter Systems at www.amsoil.com for complete information.
2. To change the filter element:
 - a. Ensure engine is off and use caution as the engine, oil and filter may be hot and could result in an injury.
 - b. Using a filter wrench, remove the filter element. Dispose of properly.
 - c. Clean the filter gasket contact area on the mount with a clean, lint-free rag.
 - d. Lubricate the new filter gasket with clean oil.
 - e. Fill filter as full as possible with the same engine oil as what is in the engine.
 - f. Screw on new filter, tighten per instructions on the filter.
 - g. Start engine and check for leaks.
 - h. Check engine oil level, fill as needed.
 - i. Record date of installation and equipment operating hours or mileage for future reference.

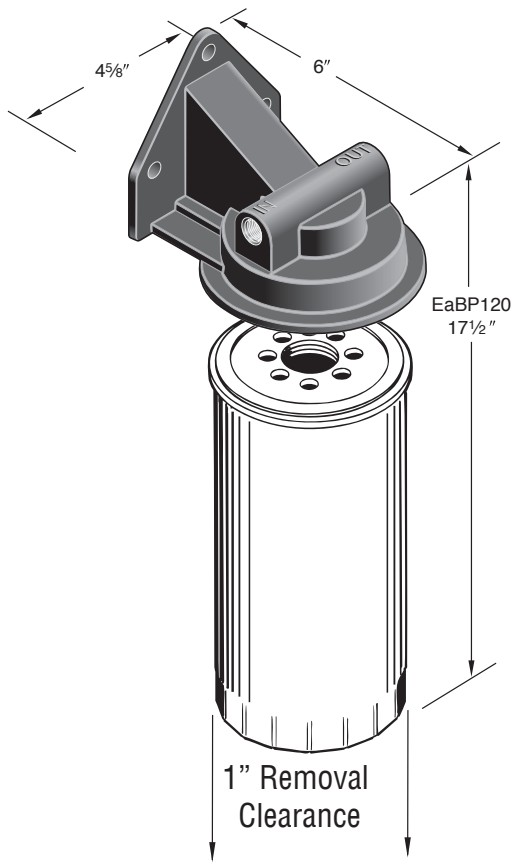

Diagram A

MINIMUM AREA NEEDED FOR MOUNT AND SPIN-ON OIL FILTER ELEMENT

* Mount and element heights plus 1-inch removal clearance

Diagram B

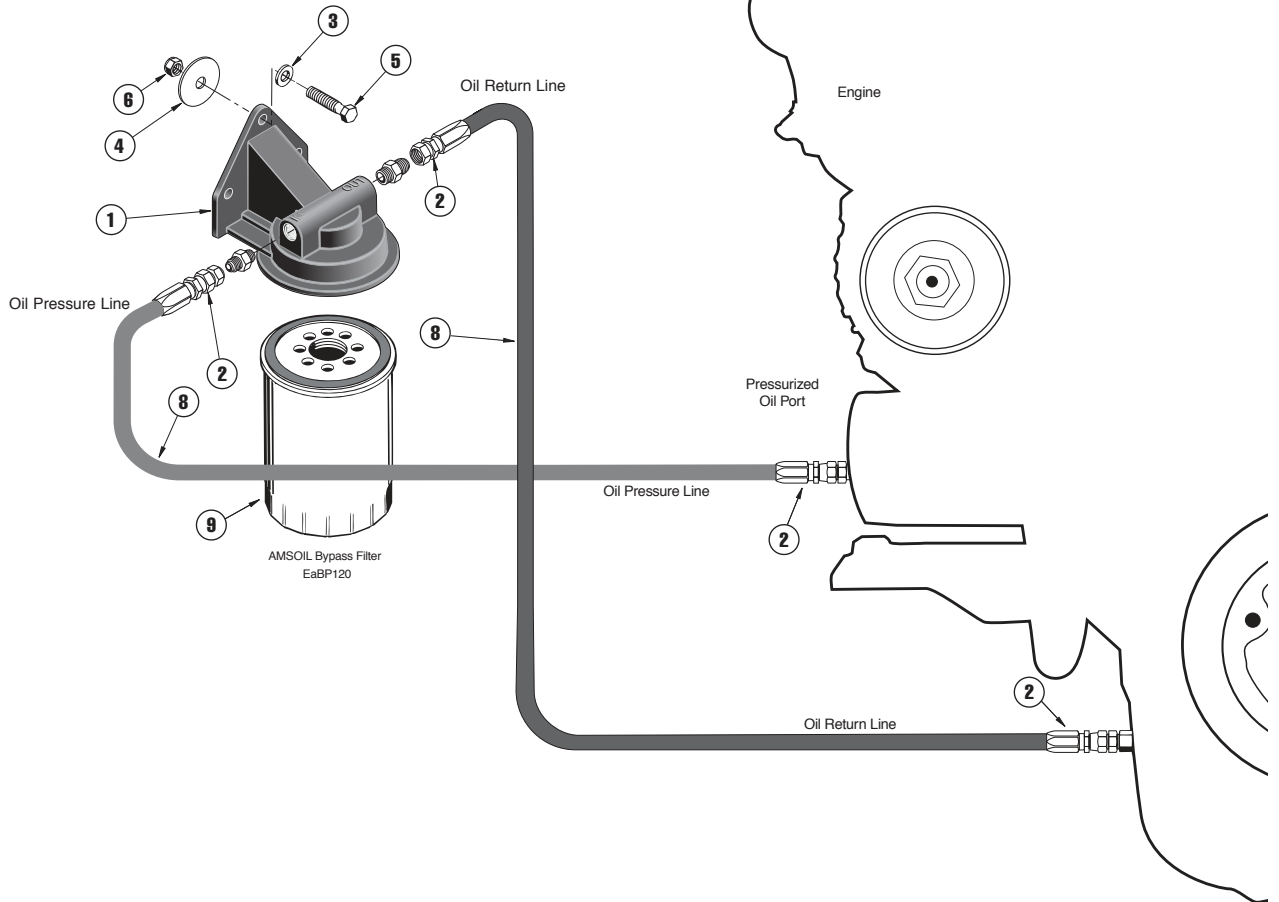
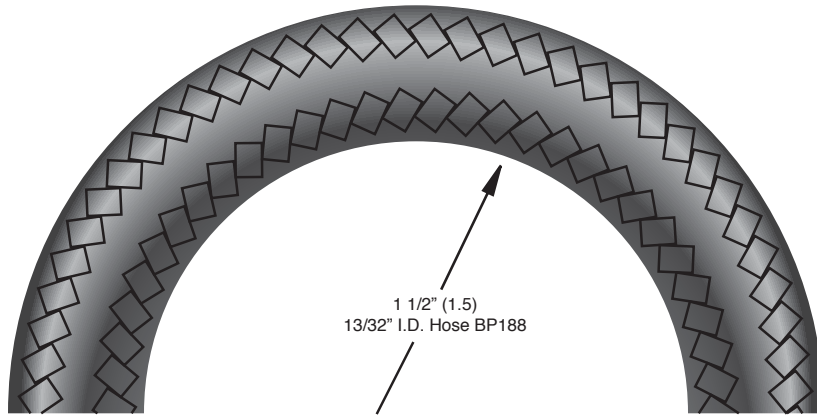

Diagram C
 Minimum Bend Radius
 (Actual Size)



Mounting Angle Diagram D

(Recommendations are the same right to left and front to back)
 Mounting angle above horizontal is not recommended

